

# DEBANGAN ESTATE PVT. LTD.

18B, NORTHERN AVENUE, P.S. - CHITPUR, P.O. - BELGACHIA, KOLKATA - 700037

Contact - 9051061069

PROPOSED G+IV STORIED (15.475 M. HEIGHT) RESIDENTIAL BUILDING PLAN OF THE PREMISES NO:- 72, PAIKPARA ROW, KOLKATA - 7000 37, WARD NO. - 004, BOROUGH NO. - I, P.S. - CHITPUR, COMPLYING KMC BUILDING RULE 2009 AND U/S 393A OF KMC BUILDING ACT 1980. UNDER THE KOLKATA MUNICIPAL CORPORATION.

## APPLICANT :-

NAME OF THE APPLICANTS :- DEBANGAN ESTATE PRIVATE LIMITED, DIRECTOR OF SRI DEBABRATA CHAKRABORTY AS CONSTITUTED ATTORNEY OF 01. SRI GOUTAM MITRA, 02. INDRANI GHOSH, 03. SANJAY MITRA, 04. SWAPNA GHOSH, 05. SAIKAT MONDAL, 06. PRITHWISH MONDAL, 07. SANTA MITRA, 08. ATANU MITRA, 09. BAISALI SEN.



Co-ordinate in WGS 84	
Latitude	Longitude
22° 36' 40.98" N	88° 23' 17.31" E

LATITUDE & LONGITUDE HAS BEEN MEASURED NEAR THE CENTER OF THE PLOT

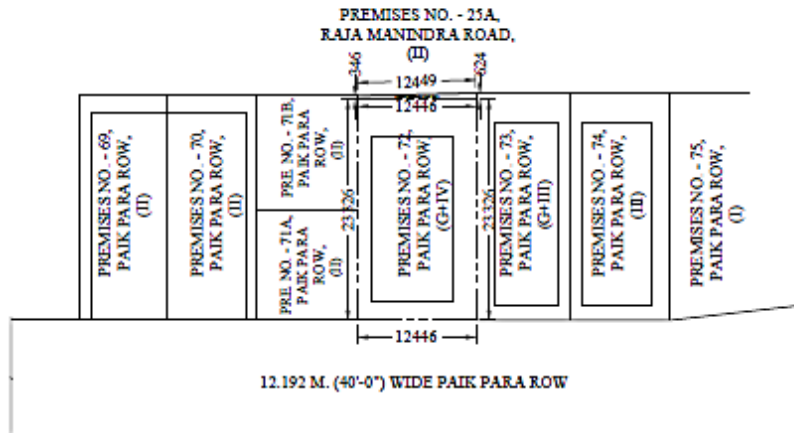

**SITE PLAN**  
(SCALE :- 1:600)

Debangan Estate Pvt.Ltd

Director